

AZ9731T

50 AMP MINI-ISO AUTOMOTIVE RELAY

FEATURES

- Quick connect terminals
- 50 Amp contact rating
- High operating temperature (125°C)
- Epoxy sealed versions available
- Plastic or steel mounting bracket available
- Resistor or diode parallel to coil available
- Suitable for automobile and lamp accessory applications



CONTACTS

Arrangement	SPST (1 Form A) SPDT (1 Form C) SPST NO DM (1 Form U) SPST (1 Form A2)
Ratings	Resistive load: Max. switched power: 700W Max. switched current: 50 A (N.O.) 40 A (N.C.) Max. switched voltage: 75 VDC 1 Form A : 50A at 14VDC 1 Form C : 50A/40A at 14VDC (N.O./N.C.) 1 Form U : 2 x 25A at 14VDC
Material	Silver tin oxide
Resistance	< 100 milliohms initially (6 V, 1 A voltage drop method)

COIL

Power	
At Pickup Voltage (typical)	0.68 W
Max. Continuous Dissipation	4.8 W at 20°C (68°F)
Temperature Rise	75°C (135°F) at nominal coil voltage (40A)
Temperature	Max. 125°C (257°F)

GENERAL DATA

Life Expectancy Mechanical Electrical	Minimum operations 1 x 10 ⁷ 1 x 10 ⁵ at 50 A, 14VDC Res.
Operate Time (max.)	7 ms at nominal coil voltage
Release Time (max.)	5 ms at nominal coil voltage
Dielectric Strength (at sea level for 1 min.)	750 Vrms coil to contact 500 Vrms contact to contact
Insulation Resistance	100 megohms min. at 500 VDC, 20°C 50% RH
Dropout	Greater than 10% of nominal coil voltage
Ambient Temperature Operating	-40°C (-40°F) to 125°C (257°F)
Vibration	0.059" DA at 10-40 Hz
Shock	15 g
Enclosure	P.B.T. polyester
Terminals	Tinned copper alloy 0.25 Quick Connect Note: Allow suitable slack on leads when wiring, and do not subject the terminals to excessive force.
Weight	31 grams

NOTES

1. All values at 20°C (68°F).
2. Relay may pull in with less than "Must Operate" value.
3. Specifications subject to change without notice.

AMERICAN ZETTLER, INC. www.azettler.com

75 COLUMBIA • ALISO VIEJO, CA 92656 • PHONE: (949) 831-5000 • FAX: (949) 831-8642 • E-MAIL: SALES@AZETTLER.COM

AZ9731T

RELAY ORDERING DATA

COIL SPECIFICATIONS			
Nominal Coil VDC	Must Operate VDC	Max. Continuous VDC	Coil Resistance $\pm 10\%$
6	3.9	7.8	22.5
12	7.8	15.6	90
24	15.6	31.2	360

RELAY ORDERING DATA

AZ9731T-1C-12DC2R1

- Blank - Standard no diode, no resistor
- R1 - 180 Ohm $\frac{1}{2}$ w resistor in parallel with 6 V coil
680 Ohm $\frac{1}{2}$ w resistor in parallel with 12 V coil
2700 Ohm $\frac{1}{2}$ w resistor in parallel with 24 V coil
- D2 - 1N4005 diode in parallel with coil, cathode on #86 terminal
- D3 - 1N4005 diode in parallel with coil, cathode on #85 terminal
- C1 - Plastic dust cover with steel mounting bracket
- C1E - Plastic dust cover with steel mounting bracket, sealed
- C2 - Plastic dust cover with plastic mounting bracket
- C2E - Plastic dust cover with plastic mounting bracket, sealed
- C3 - Plastic dust cover
- C3E - Plastic dust cover, sealed
- 24D - 24 volt coil
- 12D - 12 volt coil
- 6D - 6 volt coil
- 1A - SPNO Single pole normally open
- 1C - SPDT Single pole double throw
- 1U - SPST NO DM Single pole N.O. double make
- 1A2- SPNO Single pole normally open (2x)
- Basic series designation - AZ9731T

AMERICAN ZETTLER, INC. www.azettler.com

75 COLUMBIA • ALISO VIEJO, CA 92656 • PHONE: (949) 831-5000 • FAX: (949) 831-8642 • E-MAIL: SALES@AZETTLER.COM

AZ9731T

MECHANICAL DATA

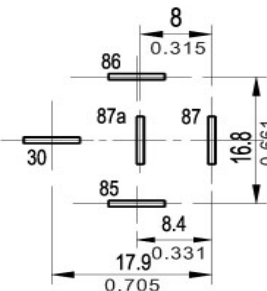
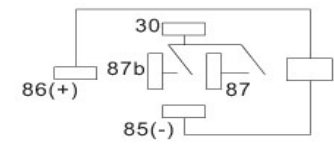
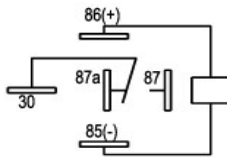
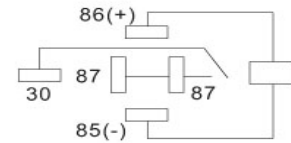
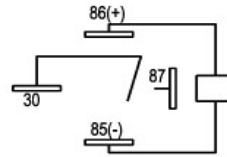
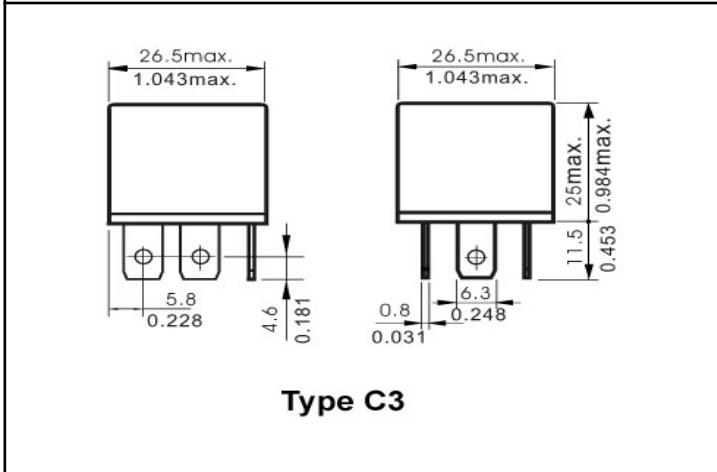
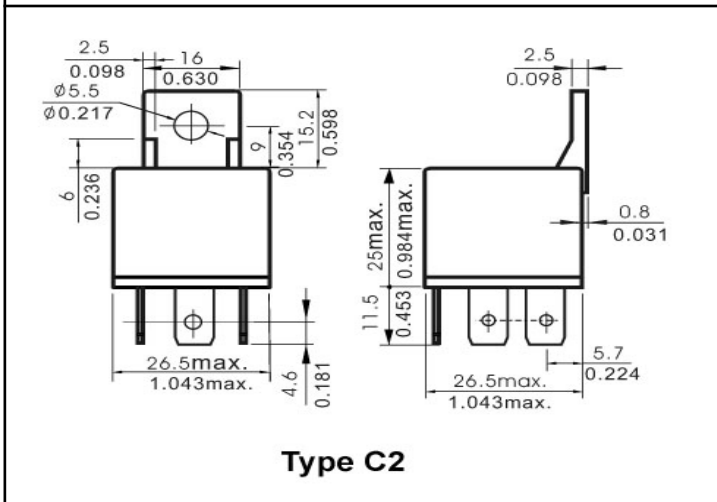
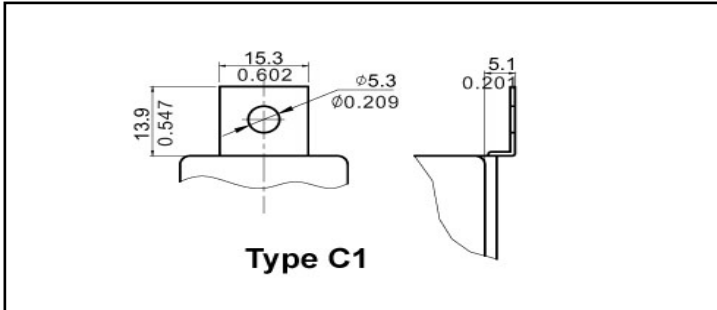

MOUNTING LAYOUT
Viewed Toward Terminals