

AZ9371

SENSITIVE SUBMINIATURE RELAY

FEATURES

- Extremely small footprint
- Thin vertical profile only 0.275" (7 mm) wide
- High sensitivity, 113 mW pickup
- Dielectric strength 4000 Vrms
- 5 Amp switching capability (version "T" 10 Amp)
- Two different footprints available
- Class B insulation (130°C) standard, Class F (155°C) available
- UL, CUR file E44211
- VDE 40030746

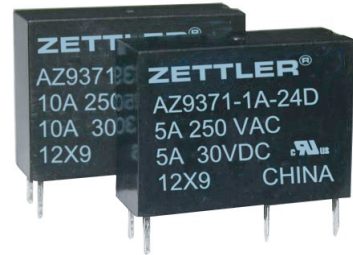

CONTACTS

Arrangement	SPST (1 Form A)
Ratings	Resistive load: Max. switched power: 150 W or 1385 VA (Version "T": 300 W or 2770 VA) Max. switched current: 5 A (Version "T": 10 A) Max. switched voltage: 30 VDC* or 277 VAC * Note: If switching voltage is greater than 30 VDC, special precautions must be taken. Please contact the factory.
Rated Load UL/CSA	5 A at 277/250/125 VAC General Use 50k cycles 85°C [1][2] 5 A at 30 VDC General Use 50k cycles 85°C [1][2] 3 A at 277/250/125 VAC General Use 120k cycles 85°C [1][2] 3 A at 30 VDC General Use 120k cycles 85°C [1][2] B300 Pilot Duty 120/240 VAC 25k cycles [2] R300 Pilot Duty 125/250 VAC 25k cycles [2]
VDE	"T" Version 10 A at 277/250/125 VAC General Use 10k cycles 85°C [1][2] 10 A at 30 VDC General Use 10k cycles 85°C [1][2] 7 A at 277/250/125 VAC General Use 60k cycles 85°C [2] 7 A at 277/250/125 VAC General Use 50k cycles 105°C [1] 7 A at 30 VDC General Use, 50k cycles 105°C [1] 7 A at 30 VDC General Use, 60k cycles 85°C [2] TV-3, 25k cycles
Material	Silver nickel [1], silver tin oxide [2], gold plating available
Resistance	< 100 milliohms initially (at 6 V, 1 A, voltage drop method)

COIL

Power	
At Pickup Voltage (typical)	113 mW
Max. Continuous Dissipation	750 mW at 20°C (68°F) ambient
Temperature Rise	26°C (47°F) at nominal coil voltage)
Temperature	Max. 130°C (266°F) Class B Max. 155°C (311°F) Class F

GENERAL DATA

Life Expectancy	Minimum operations 5 million operations
Mechanical	
Standard version	1 X 10 ⁵ at 5 A, 250 VAC res. [1] 5 X 10 ⁴ at 5 A, 250 VAC res. [2]
Electrical	
High capacity version "T"	1 X 10 ⁵ at 7 A, 250 VAC res. [1] 1 X 10 ⁴ at 10 A, 250 VAC res. [1][2] 3 X 10 ⁴ at 7 A, 250 VAC res. [2]
Electrical	
Operate Time (typical)	10 ms at nominal coil voltage
Release Time (typical)	10 ms at nominal coil voltage (with no coil suppression)
Dielectric Strength (at sea level for 1 min.)	4000 Vrms coil to contact 1000 Vrms between open contacts
Insulation Resistance	1000 megohms min. at 20°C, 500 VDC, 50% RH
Dropout	Greater than 5% of nominal coil voltage
Ambient Temperature	At nominal coil voltage
Operating	-40°C (-40°F) to 85°C (185°F)
Storage	-40°C (-40°F) to 105°C (221°F)
Vibration	0.062" (1.5 mm) DA at 10–55 Hz
Shock	10 g
Enclosure	P.B.T. polyester
Terminals	Tinned copper alloy, P.C.
Max. Solder Temp.	270°C (518°F)
Max. Solder Time	5 seconds
Max. Solvent Temp.	80°C (176°F)
Max. Immersion Time	30 seconds
Weight	3 grams

NOTES

1. All values at 20°C (68°F).
2. Relay may pull in with less than "Must Operate" value.
3. Specifications subject to change without notice.

AZ9371

RELAY ORDERING DATA

COIL SPECIFICATIONS				
Nominal Coil VDC	Must Operate VDC	Max. Continuous VDC	Coil Resistance Ohm \pm 10%	ORDER NUMBER
3	2.25	3.9	45	AZ9371-1A-3D
5	3.75	6.5	125	AZ9371-1A-5D
6	4.50	7.8	180	AZ9371-1A-6D
9	6.75	11.7	405	AZ9371-1A-9D
12	9.00	15.6	720	AZ9371-1A-12D
18	13.50	23.4	1620	AZ9371-1A-18D
24	18.00	31.2	2880	AZ9371-1A-24D

*Add "T" after "AZ9371" for high capacity version. Add "E" after "1A" to indicate silver tin oxide contacts. Add suffix "E" for sealed version. Add suffix "K" for K version footprint. Add suffix "F" for Class F version. Add suffix "G" at the end of order number for gold plated contacts.

AMERICAN ZETTLER, INC.

3/20/18

PHONE: (949) 831-5000

www.azettler.com

E-MAIL: SALES@AZETTLER.COM

AZ9371

MECHANICAL DATA

Standard Pinning Outline Dimensions

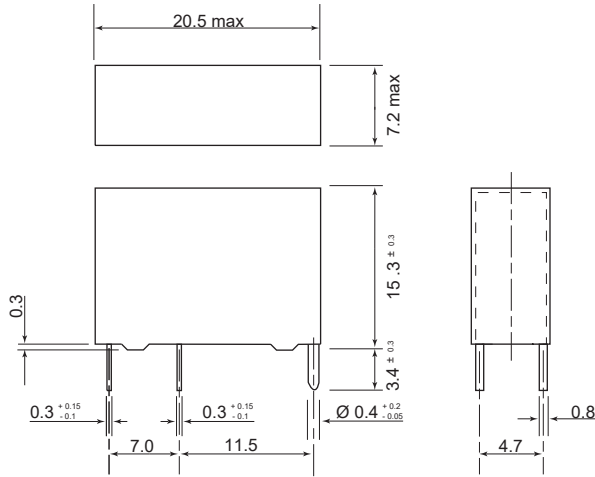

Version "K" Pinning Outline Dimensions

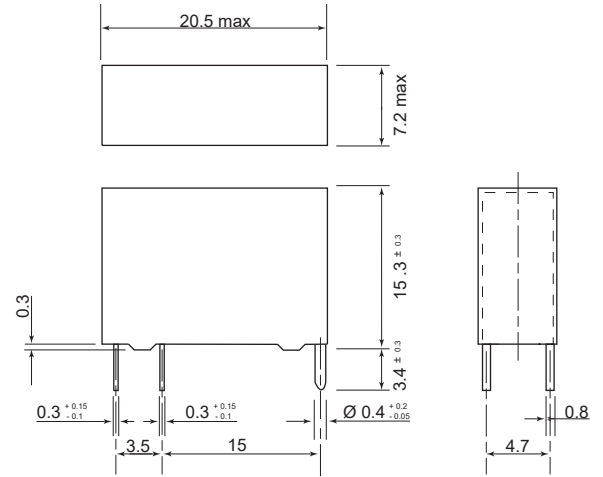

PC BOARD LAYOUT

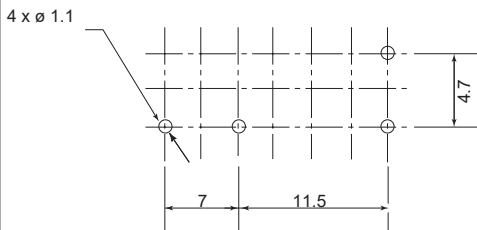

Viewed toward terminals

WIRING DIAGRAM

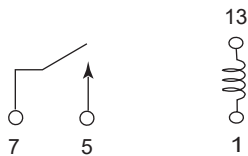

Viewed toward terminals

PC BOARD LAYOUT

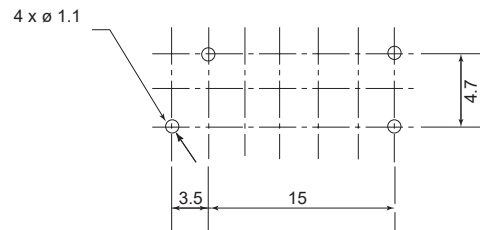

Viewed toward terminals

WIRING DIAGRAM

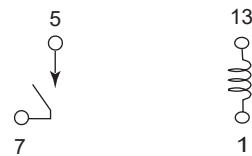

Viewed toward terminals

Attention! Grid is not 0.1" (2.54 mm)!!

AMERICAN ZETTLER, INC.

3/20/18

PHONE: (949) 831-5000

www.azettler.com

E-MAIL: SALES@AZETTLER.COM

This specification provides an overview of the most significant part features. Any individual applications and operating conditions are not taken into consideration. It is recommended to test the product under application conditions. Responsibility for the application remains with the customer. Proper operation and service life cannot be guaranteed if the part is operated outside the specified limits.