

AZ853

MICROMINIATURE POLARIZED RELAY

FEATURES

- Conforms to IEC60950/UL1950/EN60950 spacing and high breakdown voltage
Clearance: 1.0 mm (between coil and contacts)
Creepage: 1.6 mm (between coil and contacts)
Basic Insulation: 150 V Working Voltage, Pollution Degree 2
- Monostable and bistable (latching) versions available
- High dielectric and surge voltage:
2.5 KV surge (per Bellcore TA-NWT-001089)
1.5 KV surge (per FCC Part 68)
1,000 Vrms, open contacts
- Low power consumption: 79 mW pickup
- Stable contact resistance for low level signal switching
- Epoxy sealed for automatic wave soldering and cleaning
- UL file E43203; CSA file 212940
- All plastics meet UL94 V-0, 30 min. oxygen index



CONTACTS

Arrangement	DPDT (2 Form C) Bifurcated crossbar contacts
Ratings	Resistive load: Max. switched power: 60 W or 62.5 VA Max. switched current: 2.0 A Max. switched voltage: 220 VDC or 250 VAC
Rated Load UL/CSA	0.5 A at 125 VAC 2.0 A at 30 VDC 0.3 A at 110 VDC
Material	Silver alloy; gold clad
Resistance	< 75 milliohms initially at 6 V, 1 A

COIL (Polarized)

Power At Pickup Voltage (typical)	79 mW (3–12 VDC) 130 mW (24 VDC)
Max. Continuous Dissipation	1.0 W at 20°C (68°F) 0.78 W at 40°C (104°F)
Temperature Rise	At nominal coil voltage 18°C (32°F) (3–12 VDC) 25°C (45°F) (24 VDC)
Temperature	Max. 115°C (239°F)

NOTES

1. All values at 20°C (68°F).
2. Relay may pull in with less than "Must Operate" value.
3. Relay has fixed coil polarity.
4. Specifications subject to change without notice.

GENERAL DATA

Life Expectancy Mechanical Electrical	Minimum operations 1 x 10 ⁸ at 3Hz 1 x 10 ⁵ at 0.5 A, 125 VAC, Res. 2 x 10 ⁵ at 1.0 A, 30 VDC, Res.
Operate Time (typical)	3 ms at nominal coil voltage
Release Time (typical)	3 ms at nominal coil voltage (with no coil suppression)
Bounce (typical)	At 10 mA contact current 1 ms at operate or release
Capacitance	< 1 pF at 10 KHz—open contacts < 1 pF at 10 KHz—adjacent contact sets
Dielectric Strength (at sea level)	See table
Dropout	Greater than 10% of nominal coil voltage
Insulation Resistance	10 ⁹ ohms min. at 25°C, 500 VDC, 50% RH
Ambient Temperature Operating Storage	At nominal coil voltage -40°C (-40°F) to 85°C (185°F) -40°C (-40°F) to 115°C (239°F)
Vibration	Operational, 20 g, 10–55 Hz Non-destructive, 30 g, 10–55 Hz
Shock	Operational, 50 g min., 11 ms Non-destructive, 100 g min., 11 ms
Max. Solder Temp. Temp./Time	350°C (662°F) for 3 seconds 260°C (500°F) for 10 seconds
Max. Solvent Temp.	80°C (176°F)
Max. Immersion Time	30 seconds
Weight	1.0 grams
Enclosure	P.B.T. polyester
Terminals	Tinned copper alloy, P.C.

AMERICAN ZETTLER, INC.

www.azettler.com

75 COLUMBIA • ALISO VIEJO, CA 92656 • PHONE: (949) 831-5000 • FAX: (949) 831-8642 • E-MAIL: SALES@AZETTLER.COM

6/23/04W

AZ853

RELAY ORDERING DATA

NON-LATCHING VERSION				ORDER NUMBER		
Nominal Coil VDC	Max. Continuous VDC	Coil Resistance $\pm 10\%$	Must Operate VDC	THT	SMT*	SMTss*
1.5	2.25	16.1	1.13	AZ853-1.5	AZ853S-1.5	AZ853S1-1.5
3	4.5	64.3	2.25	AZ853-3	AZ853S-3	AZ853S1-3
4.5	6.75	145	3.38	AZ853-4.5	AZ853S-4.5	AZ853S1-4.5
6	9	257	4.5	AZ853-6	AZ853S-6	AZ853S1-6
9	13.5	579	6.75	AZ853-9	AZ853S-9	AZ853S1-9
12	18	1028	9.00	AZ853-12	AZ853S-12	AZ853S1-12
24	36	2504	18.00	AZ853-24	AZ853S-24	AZ853S1-24

LATCHING VERSION				ORDER NUMBER		
Nominal Coil VDC	Max. Continuous VDC	Coil Resistance $\pm 10\%$	Must Operate VDC	THT	SMT*	SMTss*
1.5	2.25	22.5	1.13	AZ853P-1.5	AZ853PS-1.5	AZ853PS1-1.5
3	4.5	90	2.25	AZ853P-3	AZ853PS-3	AZ853PS1-3
4.5	6.75	203	3.38	AZ853P-4.5	AZ853PS-4.5	AZ853PS1-4.5
6	9	360	4.50	AZ853P-6	AZ853PS-6	AZ853PS1-6
9	13.5	810	6.75	AZ853P-9	AZ853PS-9	AZ853PS1-9
12	18	1440	9.00	AZ853P-12	AZ853PS-12	AZ853PS1-12
24	36	4800	18.00	AZ853P-24	AZ853PS-24	AZ853PS1-24

*Tape and reel available (1K pcs/reel minimum)

	SURGE			
	VRMS, 1 min.	Peak (V)	Rise Time (μ S)	Decay Time* (9 μ S) (1/2 peak)
Between open contacts	1,000	1,500	10	160
Between contact sets	1,000	1,500	2	160
Between coil and contacts	1,500	2,500	2	10

* Decay time measured from beginning of surge.

Temperature Profile

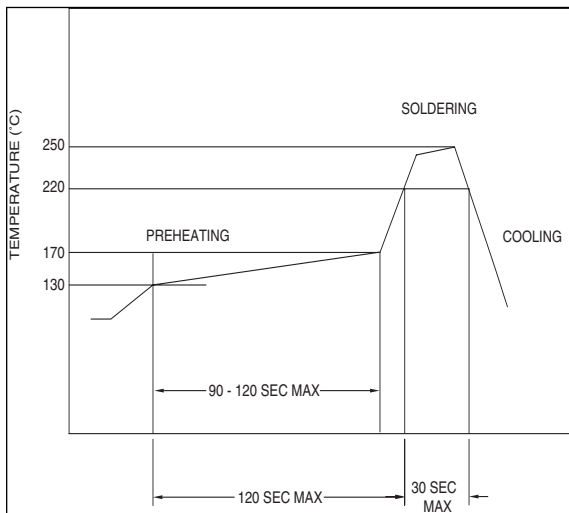

Packaging Specifications

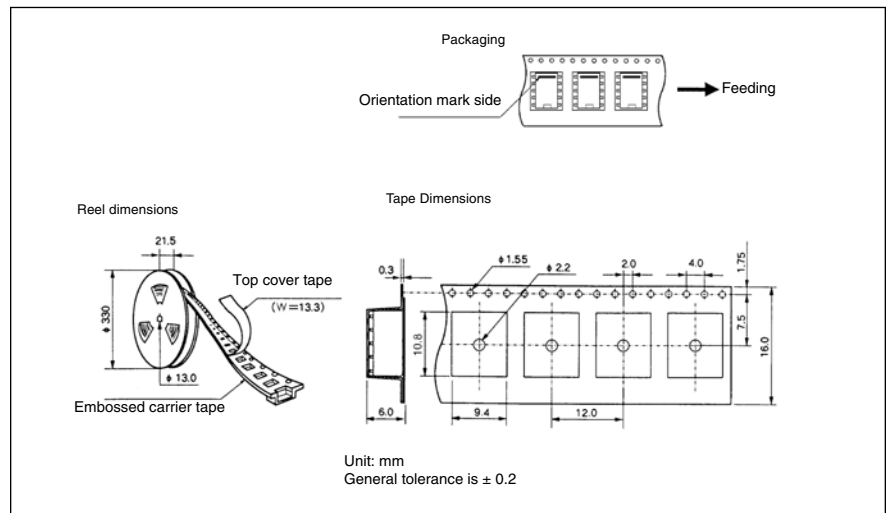

AMERICAN ZETTLER, INC.

www.azettler.com

75 COLUMBIA • ALISO VIEJO, CA 92656 • PHONE: (949) 831-5000 • FAX: (949) 831-8642 • E-MAIL: SALES@AZETTLER.COM

6/23/04W

AZ853

Mechanical Data

<p>THT</p> <p>Top view dimensions: .42 [10.6], .22 [5.7]. Side view dimensions: .35 [9.0], .020 [0.5], .14 [3.54], .016 [0.4], .09 [2.2], .09 [2.2], .126 [3.2], .06 [1.5]. End view dimensions: .126 [3.2], .008 [0.2].</p>	<p>PC Board Layout Viewed toward terminals</p> <p>Dimensions: .3 [7.6], .125 [3.2], .09 [2.2], 8-Ø.03 [Ø0.85], .125 [3.2].</p>	<p>Wiring Diagram Viewed toward terminals</p> <p>(+) 1 2 3 4 8 7 6 5 (-)</p>
<p>SMT</p> <p>Top view dimensions: .42 [10.6], .22 [5.7]. Side view dimensions: .35 [9.0], .020 [0.5], .016 [0.4], .09 [2.2], .09 [2.2], .126 [3.2], .06 [1.5]. End view dimensions: .38 [9.7], .05 [1.2], .29 [7.4], .126 [3.2], .008 [0.2].</p>	<p>PC Board Layout Viewed toward terminals</p> <p>Dimensions: .3 [7.6], .125 [3.2], .09 [2.2], 8-.124 [3.1], .21 [5.3], 8-.031 [0.8].</p>	<p>Wiring Diagram Viewed toward terminals</p> <p>(+) 1 2 3 4 8 7 6 5 (-)</p>
<p>SMTss</p> <p>Top view dimensions: .42 [10.6], .22 [5.7]. Side view dimensions: .35 [9.0], .020 [0.5], .016 [0.4], .09 [2.2], .09 [2.2], .126 [3.2], .06 [1.5]. End view dimensions: .38 [9.7], .05 [1.2], .22 [5.7], .126 [3.2], .008 [0.2].</p>		<p>Dimensions: .38 [9.7], .05 [1.2], .22 [5.7], .126 [3.2], .008 [0.2].</p>
<p>PC Board Layout Viewed toward terminals</p> <p>Dimensions: .3 [7.6], .125 [3.2], .09 [2.2], 8-.09 [2.25], .175 [4.45], 8-.03 [0.8].</p>	<p>Wiring Diagram Viewed toward terminals</p> <p>(+) 1 2 3 4 8 7 6 5 (-)</p>	

AMERICAN ZETTLER, INC.

www.azettler.com

75 COLUMBIA • ALISO VIEJO, CA 92656 • PHONE: (949) 831-5000 • FAX: (949) 831-8642 • E-MAIL: SALES@AZETTLER.COM

6/23/04W